

0.18kW to 7.5kW

Based on our standard TAI range the TAIB series is stocked from 0.18kW to 7.5kW in 4 pole only with larger ratings and polarities available upon request.



Fail Safe Design

TAIB brake motors are fitted with Intorq brand brakes and are “fail to safe” design, as the brake will engage when the power is disconnected.

Brake Connection

The TAIB three phase motor is fitted with a DC brake and half wave rectifier mounted directly in the terminal box for ease of connection to the AC supply.

- ☛ 230V Delta / 400V Star (3kW & below) fitted with 103V DC brake.
- ☛ 400V Delta / 690V Star (4kW & above) fitted with 180V DC brake.

Hand Release

As standard, all TAIB brake motors are fitted with an emergency hand release.

Mounting Arrangements

TAIB motors are available in identical mounting arrangements to that of our standard TAI aluminium series.

BRAKE MOTOR DATA

| kW | Frame Size | Intorq Brake Model | Braking Torque (Nm) | Holding Torque (Nm) | Braking Torque (%) of full load torque | Braking Time (ms) | Release Time (ms) |
|------|------------|--------------------|---------------------|---------------------|--|-------------------|-------------------|
| 0.18 | 63A-4 | BFK-457-06 | 4 | 6 | 296% | 23 | 10 |
| 0.37 | 71B-4 | BFK-457-06 | 6 | 9 | 231% | 23 | 10 |
| 0.55 | 80A-4 | BFK-457-08 | 8 | 12 | 215% | 31 | 15 |
| 0.75 | 80B-4 | BFK-457-08 | 12 | 17 | 240% | 31 | 15 |
| 1.1 | 90S-4 | BFK-457-10 | 16 | 23 | 216% | 50 | 31 |
| 1.5 | 90L-4 | BFK-457-10 | 23 | 33 | 232% | 50 | 31 |
| 2.2 | 100LA-4 | BFK-457-12 | 32 | 46 | 219% | 64 | 39 |
| 3 | 100LB-4 | BFK-457-12 | 40 | 58 | 202% | 64 | 39 |
| 4 | 112M-4 | BFK-457-14 | 60 | 87 | 227% | 51 | 26 |
| 5.5 | 132S-4 | BFK-457-16 | 70 | 101 | 195% | 70 | 40 |
| 7.5 | 132M-4 | BFK-457-16 | 100 | 145 | 202% | 70 | 40 |



TAIB SERIES MOTOR OUTLINE DIMENSIONS

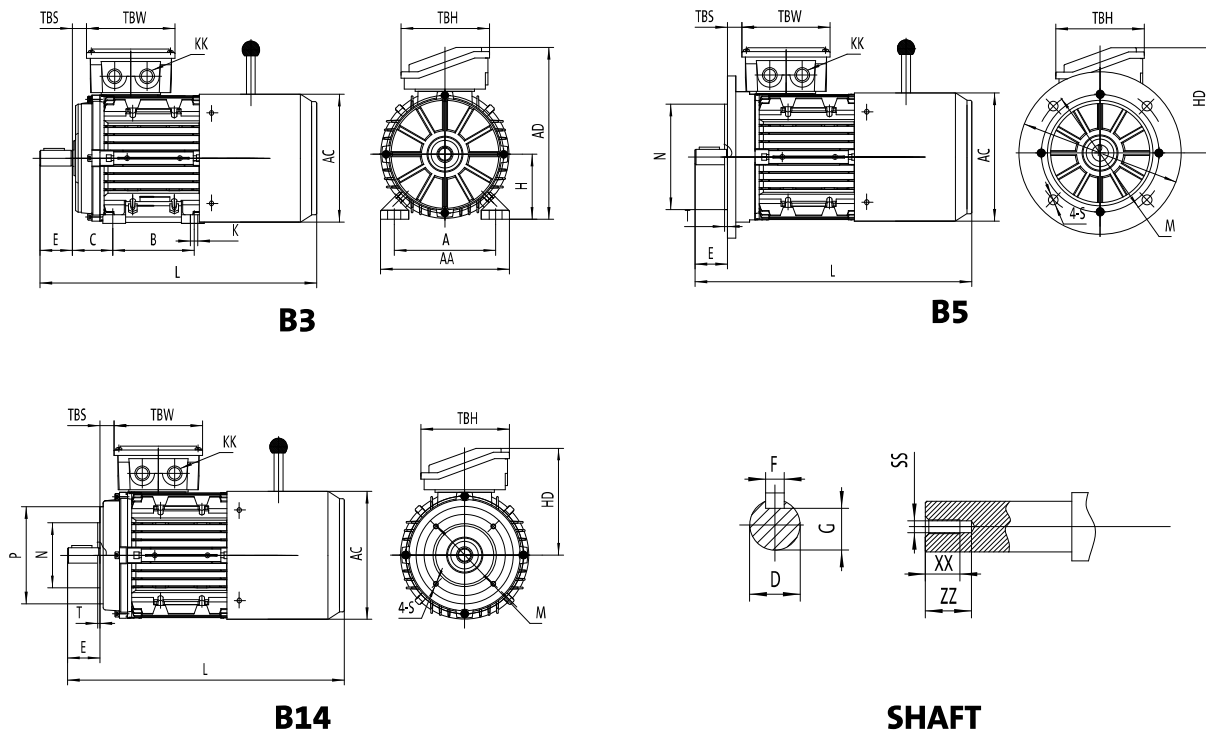

TAIB SERIES DIMENSIONAL DATA

| FRAME | Foot Mounting | | | | Shaft | | | | | | | | General | | | | | | | |
|-------------|---------------|-----|---------|----|-------|----|----|------|----|-----|----|----|---------|-----|-----|-----|---------|------|-----|-----|
| | H | A | B | C | D | E | F | G | K | SS | XX | ZZ | AA | AD | HD | AC | L | TBS | TBW | TBH |
| TAIB 63 | 63 | 100 | 80 | 40 | Φ11 | 23 | 4 | 8.5 | Φ7 | M4 | 10 | 14 | 124 | 169 | 106 | 121 | 265 | 14 | 94 | 94 |
| TAIB 71 | 71 | 112 | 90 | 45 | Φ14 | 30 | 5 | 11 | Φ7 | M5 | 12 | 17 | 140 | 184 | 113 | 139 | 301 | 20 | 94 | 94 |
| TAIB 80 | 80 | 125 | 100 | 50 | 19 | 40 | 6 | 15.5 | 9 | M6 | 16 | 21 | 160 | 214 | 134 | 158 | 341 | 18.5 | 109 | 109 |
| TAIB 90S/L | 90 | 140 | 100/125 | 56 | 24 | 50 | 8 | 20 | 10 | M8 | 19 | 25 | 175 | 233 | 143 | 177 | 366/391 | 20.5 | 109 | 109 |
| TAIB 100L | 100 | 160 | 140 | 63 | 28 | 60 | 8 | 24 | 12 | M10 | 22 | 30 | 200 | 260 | 160 | 200 | 440 | 29 | 118 | 118 |
| TAIB 112M | 112 | 190 | 140 | 70 | 28 | 60 | 8 | 24 | 12 | M10 | 22 | 30 | 230 | 283 | 171 | 220 | 465 | 30 | 118 | 118 |
| TAIB 132S/M | 132 | 216 | 140/178 | 89 | 38 | 80 | 10 | 33 | 12 | M12 | 28 | 37 | 255 | 322 | 190 | 261 | 543/581 | 34 | 118 | 118 |

| FRAME | B5 | | | | | B14A | | | | | B5R | | | | | B14B | | | | |
|-------------|-----|-----|-----|------|-----|------|-----|-----|-----|-----|-----|-----|-----|-----|----|------|-----|-----|-----|-----|
| | N | M | P | S | T | N | M | P | S | T | N | M | P | T | S | N | M | P | T | S |
| TAIB 63 | 95 | 115 | 140 | 4-10 | 3 | 60 | 75 | 90 | M5 | 2.5 | | | | | | | | | | |
| TAIB 71 | 110 | 130 | 160 | 4-10 | 3.5 | 80 | 85 | 105 | M6 | 2.5 | 95 | 115 | 140 | 3 | 10 | 95 | 115 | 140 | 3 | M8 |
| TAIB 80 | 130 | 165 | 200 | 4-12 | 3.5 | 80 | 100 | 120 | M6 | 3 | 110 | 130 | 160 | 3.5 | 10 | 110 | 130 | 160 | 3.5 | M8 |
| TAIB 90S/L | 130 | 165 | 200 | 4-12 | 3.5 | 95 | 115 | 140 | M8 | 3 | 110 | 130 | 160 | 3.5 | 10 | 110 | 130 | 160 | 3.5 | M8 |
| TAIB 100L | 180 | 215 | 250 | 4-15 | 4 | 110 | 130 | 160 | M8 | 3.5 | 130 | 165 | 200 | 3.5 | 12 | 130 | 165 | 200 | 3.5 | M10 |
| TAIB 112M | 180 | 215 | 250 | 4-15 | 4 | 110 | 130 | 160 | M8 | 3.5 | 130 | 165 | 200 | 3.5 | 12 | 130 | 165 | 200 | 3.5 | M10 |
| TAIB 132S/M | 230 | 265 | 300 | 4-15 | 4 | 130 | 165 | 200 | M10 | 3.5 | 180 | 215 | 250 | 4 | 15 | 180 | 215 | 250 | 4 | M12 |